

GENERALIZED STATISTICAL MECHANICS FOR THE N-BODY QUANTUM PROBLEM – IDEAL GASES

Sergio Curilef

Centro Brasileiro de Pesquisas Físicas

Rua Dr. Xavier Sigaud 150, 22290-180–Rio de Janeiro, RJ – Brazil

ABSTRACT

Within Tsallis generalized thermostatistics, the grand canonical ensemble is derived for quantum systems. In particular, the generalized Fermi-Dirac, Bose-Einstein and Maxwell-Boltzmann statistics are defined. The behavior of the chemical potential is depicted as a function of the temperature. Some thermodynamic quantities at high and low temperature are studied as well.

Key-words: Generalized Statistics; Non-extensive Systems; Ideal Gas.

PACS index: 05.30-d; 02.50+s; 05.70Ce; 05.90+m

I. INTRODUCTION

If the appropriate distribution function for a system is known, we can compute the expectation values of all thermodynamic quantities, such as energy and number of particles, as well as specific heat, magnetization, etc. However, the entropy still eludes us. Boltzmann, followed by Gibbs, introduced the one which yields the correct results for the thermodynamic properties of standard systems. This is

$$S = -k_B \sum_{N=0}^{\infty} \sum_i p_i^{(N)} \ln p_i^{(N)}.$$

An important property of this entropy is the extensivity (additivity).

Now, non-extensivity (or non-additivity) is an important concept in some areas of physics, by way of reference to some interesting generalizations of traditional concepts. A generalization of the Boltzmann-Gibbs statistics has been recently proposed by Tsallis [1–3] for non-extensive systems. This generalization relies on a new form for the entropy, namely

$$S_q \equiv -k \frac{1 - \sum_{N=0}^{\infty} \sum_i [p_i^{(N)}]^q}{1 - q},$$

where $q \in \mathfrak{R}$; k is a positive constant and S_q recovers its standard form, in the limit $q \rightarrow 1$.

Various properties of the usual entropy have been proved to hold for the generalized one: positivity, equiprobability, concavity and irreversibility [4]; its connection with thermodynamics is now established and suitably generalizes the standard additivity (it is non-extensive if $q \neq 1$) as well as the Shannon theorem [5].

The thermal dependence of the specific heat has been studied for some physical systems, among them, we have the $d = 1$ Ising ferromagnet [6]; a confined free particle (square well) [7]; two-level system and harmonic oscillator [8] and an anisotropic rigid rotator [9].

It is important to remark that, this formalism has already received some physical and mathematical applications. Among them, let us mention: Self-gravitating systems,

Stellar polytropes, Vlasov equation [10–13]; Lévy-like anomalous diffusion [14–17]; Correlated anomalous diffusion [18,19]; $d = 2$ Euler turbulence [10]; Self-organizing biological systems [20]; Simulated Annealing (optimization techniques in Genetics, Traveling salesman problem, Data fitting curves, quantum chemistry) [21–26]; Neural networks [27].

This generalized statistics has been shown to satisfy appropriate forms of the Ehrenfest theorem [28]; von Neumann equation [29]; Langevin and Fokker-Planck equations [19,30]; Callen's identity (used to approximatively calculate the critical temperature of the Ising ferromagnet) [31]; Fluctuation-dissipation and Onsager reciprocity theorems [32]; its connection with Quantum Groups [33], quantum uncertainty [34,35], fractals [36,37], quantum correlated many-body problems [38], finite systems [2,39], etc. has been established. In addition to this, some aspects of the generalized statistical mechanics in relation to the N-body classical problem were discussed [40,41], in order to treat more general situations than the collisionless one.

There exists an attempt to generalize the quantum (Fermi-Dirac and Bose-Einstein) statistics [42], but it was not taken into account the difficulty associated with the concomitant partition function owing to the factorization process shown in [40]. Consequently, the quantum ideal gas has not yet been adequately discussed within generalized statistics.

The micro-canonical and canonical formulations have been quite well studied up to now. In the present paper, the formalism in the grand-canonical ensemble is generalized. In Section II, the grand-partition function is obtained. In Section III, the extensions of the Hilhorst transformations to the grand canonical ensemble are shown. Along the same lines, the distribution function is generalized as well. In Section IV, the generalized chemical potential is depicted as a function of the temperature for the Fermi-Dirac, and Bose-Einstein gases. Approaches at high and low temperatures are derived.

II. OPEN SYSTEMS: GENERALIZED GRAND-PARTITION FUNCTION

In general, open systems can exchange heat and matter with its surroundings; therefore, the energy and the particle number will fluctuate. However, for systems in equilibrium we can require that both the average energy and the average particle number be fixed. To find the probability distribution, we need to get an extremum of the entropy which satisfies the above mentioned conditions. We proceed by the method of Lagrange multipliers with three constraints.

In this problem, we can require that the generalized probability distribution be normalized over all possible number of particles and all states of the system. Thus, the normalization condition takes the form

$$\sum_{N=0}^{\infty} \sum_j p_j^{(N)} = 1 \quad , \quad (1)$$

the generalized average energy is defined

$$\sum_{N=0}^{\infty} \sum_j [p_j^{(N)}]^q E_j^{(N)} = U_q \quad ; \quad (2)$$

it is also called *q-expectation value* [3] of the energy. The generalized average particle number is defined

$$\sum_{N=0}^{\infty} N \sum_j [p_j^{(N)}]^q = N_q \quad . \quad (3)$$

or *q-expectation value* of N .

To obtain the equilibrium generalized probability distribution, we must find an extremum of the Tsallis entropy subject to the above constraints. This gives us

$$\alpha_o + q \left[\alpha_E E_j^{(N)} + \alpha_N N - \frac{k}{q-1} \right] [p_j^{(N)}]^{q-1} = 0, \quad (4)$$

where α_o , α_E and α_N are the Lagrange multipliers. Let us multiply Eq.(4) by $p_j^{(N)}$ and sum. It is found

$$\frac{\alpha_o}{qk} - \frac{1}{q-1} = -\frac{\alpha_E}{k} U_q + \frac{1 - \sum_{N=0}^{\infty} \sum_j [p_j^{(N)}]^q}{1-q} - \frac{\alpha_N}{k} N_q. \quad (5)$$

If we compare the Eq.(5) with the grand potential $\Omega = U - TS - \mu N$, taking $\alpha_E = -1/T$ and $\alpha_N = \mu/T$ and defining $\Xi_q(\beta, \mu) = [(q-1)\alpha_o/qk]^{1/(q-1)}$, the obtained probability distribution for the grand-canonical ensemble is the following

$$p_j^{(N)} = [1 - \beta(1-q)(E_j^{(N)} - \mu N)]^{\frac{1}{1-q}} / \Xi_q(\beta, \mu), \quad (6)$$

where $\beta = 1/kT$, the number of particles $N = 0, 1, 2, \dots$, and $E_j^{(N)}$ represents the N-particle energy spectrum (characterized by the quantum number or set of quantum numbers j).

It is convenient to remark that in general

$$p_N \equiv \sum_j p_j^{(N)} \neq \left[\sum_j [p_j^{(N)}]^q \right]^{1/q} \equiv p^{(N)} \quad (7)$$

where p_N is the probability of having N particles (no matter the energy value) and $p^{(N)}$ is the quantity which enables us re-writing Eq.(3) as $\sum_{N=0}^{\infty} N [p^{(N)}]^q = N_q$; unless $q = 1$, p_N generically differs from $p^{(N)}$ (for instance, $\sum_{N=0}^{\infty} p_N = 1$ always, whereas in general $\sum_{N=0}^{\infty} p^{(N)} \neq 1$).

The generalized grand partition function is obtained from Eq.(6) with the aid of Eq.(1)

$$\Xi_q(\beta, \mu) = \sum_{N=0}^{\infty} \sum_j [1 - \beta(1-q)(E_j^{(N)} - \mu N)]^{\frac{1}{1-q}}. \quad (8)$$

On the other hand, we can also obtain the fundamental equation for open systems, this takes the following form

$$\Omega_q = -kT \frac{\Xi_q^{1-q} - 1}{1-q}; \quad (9)$$

and it is similar to the fundamental equation for closed systems (canonical ensemble [5]).

The average particle number is given by,

$$N_q = \frac{\partial \Omega_q}{\partial \mu} = -kT \frac{1}{(\Xi_q)^q} \frac{\partial \Xi_q}{\partial \mu}. \quad (10)$$

For a quantum system the expression for the probability density operator ρ being given by

$$\rho = \frac{[1 - \beta(1-q)(\mathbf{H} - \mu \mathbf{N})]^{\frac{1}{1-q}}}{\Xi_q}, \quad (11)$$

where \mathbf{H} refers to the Hamiltonian of the system and \mathbf{N} to the particle number operator. The grand-partition function is given by

$$\Xi_q = Tr [1 - \beta(1 - q)(\mathbf{H} - \mu\mathbf{N})]^{\frac{1}{1-q}}. \quad (12)$$

The trace in Eq.(12) can be evaluated regarding some convenient set of basis states.

III. HILHORST INTEGRAL TRANSFORMATIONS AND GENERALIZED DISTRIBUTION FUNCTION

The so called Hilhorst integral transformations [2] and the extension for $q < 1$ shown by Prato [41] are important because they connect a thermodynamic or statistical generalized quantity to its respective standard quantity. Therefore, an extension of the Hilhorst integral to the grand-canonical ensemble is derived. From the representation of the Gamma function we have

$$\eta^{-\nu} = \frac{1}{\Gamma(\nu)} \int_0^\infty d\xi \xi^{\nu-1} e^{-\eta\xi}. \quad (13)$$

Using this expression in the generalized grand partition function (8) with the identifications $\nu = 1/(q - 1)$ and $\eta = 1 + \beta(q - 1)(E_j^{(N)} - \mu N)$, it is obtained

$$\Xi_q(\beta, \mu) = \frac{1}{\Gamma(\frac{1}{q-1})} \sum_{N=0}^{\infty} \sum_j \int_0^\infty d\xi \xi^{\frac{1}{q-1}-1} \exp\left(-[1 + \beta(q - 1)(E_j^{(N)} - \mu N)]\xi\right). \quad (14)$$

Whenever

$$\sum_{N=0}^{\infty} \sum_j \int_0^\infty d\xi = \int_0^\infty d\xi \sum_{N=0}^{\infty} \sum_j, \quad (15)$$

Eq.(14) becomes

$$\Xi_q(\beta, \mu) = \frac{1}{\Gamma(\frac{1}{q-1})} \int_0^\infty d\xi \xi^{\frac{1}{q-1}-1} \sum_{N=0}^{\infty} \sum_j \exp\left(-[1 + \beta(q - 1)(E_j^{(N)} - \mu N)]\xi\right). \quad (16)$$

Finally, it is obtained

$$\Xi_q(\beta, \mu) = \frac{1}{\Gamma(\frac{1}{q-1})} \int_0^\infty d\xi \xi^{\frac{1}{q-1}-1} e^{-\xi} \Xi_1(\beta(q - 1)\xi, \mu), \quad (17)$$

for $q > 1$; and (see [41])

$$\Xi_q(\beta, \mu) = \Gamma\left(\frac{2-q}{1-q}\right) \frac{i}{2\pi} \oint_C d\xi (-\xi)^{\frac{-1}{1-q}-1} e^{-\xi} \Xi_1(-\beta(1-q)\xi, \mu), \quad (18)$$

for $q < 1$. The contour C in the complex plane is depicted in FIG. 1. The connection between Eq.(17) and Eq.(18) is shown in Appendix A.

Now, we write similar transformations for the q -expectation value of the energy. It is obtained

$$U_q = \sum_l \frac{1}{[\Xi_q(\beta)]^q \Gamma\left(\frac{q}{q-1}\right)} \int_0^\infty d\xi \xi^{\frac{1}{q-1}} e^{-\xi} \Xi_1(\beta(q-1)\xi, \mu) U_1(\beta(q-1)\xi) \quad (19)$$

for $q > 1$ (for the canonical ensemble it is shown in [9]); and

$$U_q = \frac{\Gamma\left(\frac{1}{1-q}\right)}{[\Xi_q(\beta)]^q} \frac{i}{2\pi} \oint_C d\xi (-\xi)^{\frac{-1}{1-q}} e^{-\xi} \Xi_1(-\beta(1-q)\xi, \mu) U_1(-\beta(1-q)\xi) \quad (20)$$

for $q < 1$.

Similar expressions are obtained for the q -expectation value of the particle number

$$N_q = \frac{1}{[\Xi_q(\beta)]^q \Gamma\left(\frac{q}{q-1}\right)} \int_0^\infty d\xi \xi^{\frac{1}{q-1}} e^{-\xi} \Xi_1(\beta(q-1)\xi, \mu) N_1(\beta(q-1)\xi) \quad (21)$$

for $q > 1$; and

$$N_q = \frac{\Gamma\left(\frac{1}{1-q}\right)}{[\Xi_q(\beta)]^q} \frac{i}{2\pi} \oint_C d\xi (-\xi)^{\frac{-1}{1-q}} e^{-\xi} \Xi_1(-\beta(1-q)\xi, \mu) N_1(-\beta(1-q)\xi) \quad (22)$$

for $q < 1$.

Finally, let us also write the generalized distribution function in the Hilhorst manner. We remark that a double sum over all possible number of particles and all states of the systems appears at each quantity, in particular, the average particle number (3). The double sum can be transformed to one only sum over all states of a single particle by standard methods.

Now, let us remember that

$$N_1 = \sum_l n_{1l}, \quad (23)$$

where n_{1l} is known as the distribution function and it is very well defined in the Maxwell-Boltzmann, Bose-Einstein and Fermi-Dirac statistics. By replacing Eq.(23) into Eq.(21) and Eq.(22), we obtain the generalized distribution functions. We define

$$n_{ql} = \frac{1}{[\Xi_q(\beta)]^q \Gamma(\frac{q}{q-1})} \int_0^\infty d\xi \xi^{\frac{1}{q-1}} e^{-\xi \Xi_1(\beta(q-1)\xi)} n_{1l}(\beta(q-1)\xi) \quad (24)$$

for $q > 1$; and

$$n_{ql} = \frac{\Gamma(\frac{1}{1-q})}{[\Xi_q(\beta)]^q} \frac{i}{2\pi} \oint_C d\xi (-\xi)^{\frac{-1}{1-q}} e^{-\xi \Xi_1(-\beta(1-q)\xi)} n_{1l}(-\beta(1-q)\xi) \quad (25)$$

for $q < 1$.

Therefore, we have defined the generalized distribution functions in connection with the standard distribution and partition functions through Eq.(24) and Eq.(25). In addition, we have

$$N_q = \sum_l n_{ql} \quad (26)$$

which is the generalization of the Eq.(23).

IV. APPLICATIONS TO QUANTUM IDEAL GASES

The statistics of N-body quantum systems plays a crucial role in determining the thermodynamic behavior at very low temperature. It is known however that, in the standard framework, there is no difference between Bose-Einstein and Fermi-Dirac statistics at high temperature. Maxwell-Boltzmann statistics is the name given to the statistics which describes the behavior of the systems at high temperature.

The quantum state $E_l^{(N)}$ of the system is specified by the one-particle states. The total energy is given by

$$E_l^{(N)} = \epsilon_{l_1} + \epsilon_{l_2} + \dots + \epsilon_{l_N} = n_1 \epsilon_1 + n_2 \epsilon_2 + \dots + n_\infty \epsilon_\infty$$

Where ϵ_i is the energy of the state and n_i is the occupation number, we have also $n_1 + n_2 + \dots + n_\infty = N$. The generalized grand partition function for the Maxwell-Boltzmann statistics can be written as

$$\Xi_q^{M-B} = \sum_{N=0}^{\infty} \frac{1}{N!} \sum_{l_1} \sum_{l_2} \dots \sum_{l_N} [1 - \beta(1-q)(\epsilon_{l_1} + \epsilon_{l_2} + \dots + \epsilon_{l_N} - N\mu)]^{\frac{1}{1-q}}, \quad (27)$$

where we have inserted the factor $1/N!$ in the same way as in the $q = 1$ statistics, because it gives us the proper form of the grand partition function for indistinguishable particles at high temperature.

The generalized grand partition function in Fermi-Dirac statistics, according to Pauli exclusion principle, is given by

$$\Xi_q^{F-D} = \sum_{N=0}^{\infty} \sum_{l_1} \sum_{l_2=l_1+1}^{\infty} \dots \sum_{l_N=l_{N-1}+1}^{\infty} [1 - \beta(1-q)(\epsilon_{l_1} + \epsilon_{l_2} + \dots + \epsilon_{l_N} - N\mu)]^{\frac{1}{1-q}}. \quad (28)$$

Each different set of occupation number corresponds to one possible state. Sometimes, it is convenient to write the partition function by the equivalent form

$$\Xi_q^{F-D} = \sum_{n_o=0}^1 \dots \sum_{n_j=0}^1 \dots \sum_{n_{\infty}=0}^1 \left[1 - \beta(1-q) \sum_l n_l (\epsilon_l - \mu) \right]^{\frac{1}{1-q}}. \quad (29)$$

The exclusion principle restricts the occupation number (n_i) of each state to 0 or 1.

The generalized grand partition function in Bose-Einstein statistics is given by

$$\Xi_q^{B-E} = \sum_{N=0}^{\infty} \sum_{l_1} \sum_{l_2=l_1}^{\infty} \dots \sum_{l_N=l_{N-1}}^{\infty} [1 - \beta(1-q)(\epsilon_{l_1} + \epsilon_{l_2} + \dots + \epsilon_{l_N} - N\mu)]^{\frac{1}{1-q}}. \quad (30)$$

Here, there is no restriction on the number of particles that can occupy a given momentum state. Another form for this partition function is

$$\Xi_q^{B-E} = \sum_{n_o=0}^{\infty} \dots \sum_{n_j=0}^{\infty} \dots \sum_{n_{\infty}=0}^{\infty} \left[1 - \beta(1-q) \sum_l n_l (\epsilon_l - \mu) \right]^{\frac{1}{1-q}}. \quad (31)$$

The occupation number (n_i) of each momentum state can be 0,1,2,...

A. Particles with Periodic Boundary Conditions

We consider a gas of non-interacting particles of mass m with the condition $\exp(ik_l\ell) = 1$, so $k_l\ell = 2\pi l$ and $l = 0, \pm 1, \pm 2, \pm 3, \dots$

The spectrum for a single particle is given by

$$\epsilon_l = \frac{\hbar^2 k_l^2}{2m} = \frac{\hbar^2}{2m} \left(\frac{2\pi l}{\ell} \right)^2$$

where $\hbar = h/2\pi$ (h is the Planck constant).

1. High-Temperature Approach

In order to find Ξ_q^{M-B} in connection with Ξ_1^{M-B} (Eq.(17) and Eq.(18)), we write Ξ_1^{M-B} conveniently. Thus, the grand partition function within $q = 1$ statistics is given by

$$\Xi_1^{M-B} = \sum_{N=0}^{\infty} \frac{e^{N\beta\mu}}{N!} \left[\sum_l e^{-\beta\epsilon_l} \right]^N. \quad (32)$$

If the volume is large enough, the particle energies will be closely spaced and we can replace the sum over l by an integral over a continuous variable k . Thus,

$$\sum_{l=-\infty}^{\infty} e^{-\beta\epsilon_l} \rightarrow \left(\frac{\ell}{2\pi} \right)^D \frac{2\pi^{D/2}}{\Gamma(D/2)} \int_0^{\infty} dk k^{D-1} e^{-\beta\hbar^2 k^2/2m}, \quad (33)$$

where D is the dimension. Hence, Ξ_1^{M-B} becomes

$$\Xi_1^{M-B} = \sum_{N=0}^{\infty} \frac{1}{N!} e^{N\beta\mu} \left(\frac{m\ell^2}{2\pi\hbar^2\beta} \right)^{ND/2}, \quad (34)$$

Replacing Eq.(34) into Eq.(18), we obtain:

$$\Xi_q^{M-B} = \sum_{N=0}^{\infty} \frac{\Gamma(\frac{2-q}{1-q}) [1 + \beta(1-q)\mu N]^{\frac{1}{1-q} + \frac{ND}{2}}}{N!(1-q)^{DN/2} \Gamma(\frac{2-q}{1-q} + \frac{ND}{2})} \left(\frac{m\ell^2}{2\pi\hbar^2\beta} \right)^{ND/2}, \quad (35)$$

for $q < 1$.

2. Fermi-Dirac Gas at Zero-temperature Limit

The average particle number at low temperature is given by (see Appendix B)

$$N_1 = \frac{2}{\Gamma(D/2)} \left(\frac{m\ell^2}{2\pi\hbar^2} \right)^{D/2} \left[\frac{\mu^{D/2}}{D} + \sum_{n=1}^{\infty} g_n(\mu, D) (k_B T)^{2n} \right]. \quad (36)$$

We solve Eq.(22) with the aid of Eq.(36) for $q < 1$

$$\begin{aligned} \frac{N_q}{\Gamma(\frac{1}{1-q}) A_F^{(D)} / \Xi_q(\beta)^q} &= \frac{\mu^{D/2}}{D} \frac{i}{2\pi} \oint_C d\xi (-\xi)^{\frac{-1}{1-q}} e^{-\xi} \Xi_1 + \\ &+ \sum_{n=1}^{\infty} g_n(D, \mu) (\beta(1-q))^{-2n} \frac{i}{2\pi} \oint_C d\xi (-\xi)^{\frac{-1}{1-q} - 2n} e^{-\xi} \Xi_1. \end{aligned} \quad (37)$$

where $A_F^{(D)}$ is defined in Eq.(B4). Finally

$$\begin{aligned} \frac{N_q}{A_F^{(D)}} &= \frac{\mu^{D/2}}{D} 1_q + \\ &+ \sum_{n=1}^{\infty} \frac{g_n(D, \mu) \Gamma(\frac{1}{1-q})}{(1-q)^{2n} \Gamma(\frac{1}{1-q} + 2n)} \left([kT - (1-q)(\mathbf{H} - \mu\mathbf{N})]^{2n} \right)_q. \end{aligned} \quad (38)$$

Here 1_q is the q -expectation values of 1 and it is a function of T ; in general $1_q \neq 1$, unless $q = 1$. It is easy to verify that in the limit $q \rightarrow 1$, Eq.(38) is reduced to Eq.(36). Now, the generalized Fermi level obeys the following expresion,

$$N_q = \frac{2}{\Gamma(D/2)} \left(\frac{m\ell^2}{2\pi\hbar^2} \right)^{D/2} \left[\frac{\epsilon_F^{D/2}}{D} \lim_{T \rightarrow 0} 1_q + \sum_{n=1}^{\infty} \frac{g_n(D, \epsilon_F) \Gamma(\frac{1}{1-q})}{\Gamma(\frac{1}{1-q} + 2n)} \lim_{T \rightarrow 0} \left((\mathbf{H} - \epsilon_F \mathbf{N})^{2n} \right)_q \right] \quad (39)$$

Now, we can verify that the sum vanishes when $q \rightarrow 1$, because

$$\lim_{q \rightarrow 1} \frac{\Gamma(\frac{1}{1-q})}{\Gamma(\frac{1}{1-q} + 2n)} = \lim_{q \rightarrow 1} (1-q)^{2n} = 0$$

thus, Eq.(39) is reduced to the known result for the Fermi level in Boltzmann-Gibbs statistics when $q \rightarrow 1$.

B. Particles in a Box

We consider a gas of non-interacting particles into a box. The spectrum for a single particle is given by

$$\epsilon_l = \frac{\hbar^2}{2m} \left(\frac{\pi l}{\ell} \right)^2$$

where $l = 1, 2, 3, \dots$ and ℓ is the side of the box.

The chemical potential as function of the temperature is depicted in FIG. 2 for $q = 1$, typical values of N_1 and $D = 1$; the thermodynamic limit is easily computed. See the Fermi-Dirac case in FIG. 2.(a) and the Bose-Einstein case in FIG. 2.(b).

In the Boltzmann-Gibbs statistics the exponential form of the probability distribution allows for the explicit integration, in evaluating the partition function Ξ_1 , of the momentum-dependent part (kinetic energy) of $\exp(-\beta\mathbf{H})$. This fact, reduces the work involved in computing Ξ_1 of the evaluation over just the configuration variables of the one-body configuration space. It is clear, this interesting property is lost for $q \neq 1$.

The behavior at high temperature of the generalized partition function for $q < 1$ is given by

$$\Xi_q^{M-B} = \sum_{N=0}^{\infty} \frac{1}{2^{DN}} \sum_{m=0}^{DN} \frac{(-)^{DN-m} (DN)! \Gamma(\frac{2-q}{1-q}) [1 + \beta(1-q)\mu N]^{\frac{1}{1-q} + \frac{m}{2}}}{(DN-m)! m! N! (1-q)^{m/2} \Gamma(\frac{2-q}{1-q} + \frac{m}{2})} \left(\frac{2m\ell^2}{\pi \hbar^2 \beta} \right)^{m/2}, \quad (40)$$

for particles into a box in D dimensions.

The computation is very slow when q differs from the unity. FIG. 3 depicts the chemical potential versus temperature for $q = 0.8$ (see Fermi-Dirac case in FIG. 3(a) and Bose-Einstein case in FIG. 3(b)). The thermodynamic limit in (a) is found by extrapolating (to the origin) the trend of the chemical potential with $1/N_q$ for fixed temperature T . It was not reliable to do the same in (b) because all generalized quantities converge very slowly, which made numerically inaccessible the region $N_q > 6$.

CONCLUSIONS

It is well established the connection between the generalized statistical mechanics in the grand canonical ensemble with thermodynamics through the relation given by Eq.(9).

Following along the lines of the Hilhorst integral transformations for the grand partition function Ξ_q , we have obtained the analogous expressions for the appropriate averages of the particle number and the energy in the grand-canonical ensemble. In the same style, the generalized distribution functions are defined as well.

It is clear that the statistical and thermodynamic quantities transform to their standard forms in the $q \rightarrow 1$ limit, as it has been shown in some cases.

ACKNOWLEDGMENTS

The author is very indebted to C. Tsallis and D. Prato for valuable discussions and to C. Tsallis, S.A. Cannas, D.A. Stariolo, A. M. de Souza and M. Muniz for their helpful comments on the draft version of this paper. This work has benefitted from partial sup-

port from the Fundación Andes/Vitae/Antorchas, grant 12021-10. Part of the numerical calculation was carried out on a CRAY Y-MP2E of the supercomputing center at UFRGS.

APPENDIX A

By taking z as variable of integration, $F(z, \mu) = e^{-z}\Xi_1(-\beta(1-q)z, \mu)$ and $\alpha = 1/(1-q)$; the integral in Eq.(18) can be written as

$$\oint_C dz (-z)^{-\alpha-1} F(z, \mu) = \left(\int_{ab} + \int_{bcd} + \int_{de} \right) dz (-z)^{-\alpha-1} F(z, \mu), \quad (\text{A1})$$

where ab , bcd and de are lines of C shown in FIG. 1. If we use $z = \xi$ for the integral along the line ab , $z = \epsilon e^{i\theta}$ along the line bcd and $z = \xi e^{2i\pi}$ along the line de , we have

$$\begin{aligned} \oint_C dz (-z)^{-\alpha-1} F(z, \mu) &= -e^{i\alpha\pi} \int_{\infty}^{\epsilon} d\xi \xi^{-\alpha-1} e^{-\xi} \Xi_1(-\beta(1-q)\xi, \mu) \\ &\quad - \epsilon^{-\alpha} e^{i\alpha} \int_0^{2\pi} d(e^{i\theta}) (e^{i\theta})^{-\alpha-1} e^{-\epsilon e^{i\theta}} \Xi_1(-\beta(1-q)\epsilon e^{i\theta}, \mu) \\ &\quad - e^{-i\alpha\pi} \int_{\epsilon}^{\infty} d\xi \xi^{-\alpha-1} e^{-\xi} \Xi_1(-\beta(1-q)\xi, \mu). \end{aligned} \quad (\text{A2})$$

Now, putting $q > 1$ and $\epsilon \rightarrow 0$ we can see that the second integral vanishes. Thus,

$$\oint_C dz (-z)^{-\alpha-1} F(z, \mu) = -2i \sin\left(\frac{\pi}{q-1}\right) \int_0^{\infty} d\xi \xi^{\frac{1}{q-1}-1} e^{-\xi} \Xi_1(\beta(q-1)\xi, \mu) \quad (\text{A3})$$

On the other hand, we have the following property of the Γ function

$$\Gamma(p)\Gamma(1-p) = \frac{\pi}{\sin \pi p}. \quad (\text{A4})$$

Using the Eq.(A3) and Eq.(A4) into Eq.(18), we obtain

$$\Xi_q(\beta, \mu) = \frac{1}{\Gamma\left(\frac{1}{q-1}\right)} \int_0^{\infty} d\xi \xi^{\frac{1}{q-1}-1} e^{-\xi} \Xi_1(\beta(q-1)\xi, \mu). \quad (\text{A5})$$

Summarizing, we have recovered Eq.(17) from Eq.(18).

APPENDIX B

The average particle number N_1 for a fermion system in the large enough volume approach is given by

$$N_1 = \left(\frac{\ell}{2\pi}\right)^D \int d^D \vec{k} \frac{1}{\exp(\beta(\epsilon_{\vec{k}} - \mu)) + 1}. \quad (\text{B1})$$

Thus

$$N_1 = \left(\frac{\ell}{2\pi}\right)^D \frac{2\pi^{D/2}}{\Gamma(D/2)} \frac{1}{2} \left(\frac{2m}{\hbar^2}\right)^{D/2} \int_0^\infty d\epsilon_k \frac{\epsilon_k^{D/2-1}}{\exp(\beta(\epsilon_k - \mu)) + 1}. \quad (\text{B2})$$

Let us transform this integral with the following change of variable $\epsilon_k - \mu = kTz$,

$$N_1 = \left(\frac{\ell}{2\pi}\right)^D \frac{2\pi^{D/2}}{\Gamma(D/2)} \left(\frac{2m}{\hbar^2}\right)^{D/2} \frac{kT}{2} \int_{-\mu/kT}^\infty dz \frac{(\mu + kTz)^{D/2-1}}{e^z + 1}. \quad (\text{B3})$$

Defining

$$A_F^{(D)} = \left(\frac{\ell}{2\pi}\right)^D \frac{2\pi^{D/2}}{\Gamma(D/2)} \left(\frac{2m}{\hbar^2}\right)^{D/2} = \frac{2}{\Gamma(D/2)} \left(\frac{m\ell^2}{2\pi\hbar^2}\right)^{D/2}, \quad (\text{B4})$$

the integral can be written as:

$$\frac{N_1}{kT A_F^{(D)}/2} = \int_0^{\mu/kT} dz \frac{(\mu - kTz)^{D/2-1}}{e^{-z} + 1} + \int_0^\infty dz \frac{(\mu + kTz)^{D/2-1}}{e^z + 1}. \quad (\text{B5})$$

Using the simple transformation

$$\frac{1}{e^{-z} + 1} = 1 - \frac{1}{e^z + 1} \quad (\text{B6})$$

in the first integral, then

$$\begin{aligned} \frac{N_1}{kT A_F^{(D)}/2} &= \int_0^{\mu/kT} dz (\mu - kTz)^{D/2-1} \\ &\quad - \int_0^{\mu/kT} dz \frac{(\mu - kTz)^{D/2-1}}{e^z + 1} + \int_0^\infty dz \frac{(\mu + kTz)^{D/2-1}}{e^z + 1}. \end{aligned} \quad (\text{B7})$$

The second integral converges very fast; therefore, if T vanishes the upper limit can be replaced by ∞ , so

$$\frac{N_1}{kT A_F^{(D)}/2} = \frac{\mu^{D/2}}{(D/2)kT} + \int_0^\infty dz \frac{(\mu + kTz)^{D/2-1} - (\mu - kTz)^{D/2-1}}{e^z + 1}. \quad (\text{B8})$$

Finally

$$N_1 = \frac{2}{\Gamma(D/2)} \left(\frac{m\ell^2}{2\pi\hbar^2}\right)^{D/2} \left[\frac{\mu^{D/2}}{D} + \sum_{n=1}^\infty g_n(\mu, D) (k_B T)^{2n} \right], \quad (\text{B9})$$

where

$$g_n(\mu, D) = (D/2 - 1)(D/2 - 2) \cdots (D/2 - 2n + 1)(1 - 2^{1-2n})\mu^{D/2-2n}\xi(2n), \quad (\text{B10})$$

and $\xi(2n)$ is the Riemann function:

$$\xi(\eta) = \sum_{m=1}^{\infty} \frac{1}{m^\eta}.$$

In the same approach, the average energy U_1 is given by

$$U_1 = \left(\frac{\ell}{2\pi}\right)^D \int d^D \vec{k} \frac{\epsilon_{\vec{k}}}{\exp(\beta(\epsilon_{\vec{k}} - \mu)) + 1}, \quad (\text{B11})$$

then, we obtain

$$U_1 = \frac{2}{\Gamma(D/2)} \left(\frac{m\ell^2}{2\pi\hbar^2}\right)^{D/2} \left[\frac{\mu^{D/2+1}}{D+2} + \sum_{n=1}^{\infty} h_n(\mu, D)(k_B T)^{2n} \right], \quad (\text{B12})$$

where

$$h_n(\mu, D) = (D/2)(D/2 - 1) \cdots (D/2 - 2n + 2)(1 - 2^{1-2n})\mu^{D/2-2n+1}\xi(2n). \quad (\text{B13})$$

FIGURES

FIG. 1.

Contour C in the complex plane.

FIG. 2.

Chemical potential for (a) Fermi-Dirac and (b) Bose-Einstein cases for $D = 1$ and typical values of N_1 within Boltzmann-Gibbs statistics ($q = 1$). The thermodynamic limit is shown in each case.

FIG. 3.

Chemical potential for the (a) Fermi-Dirac, (b) Bose-Einstein cases for $D = 1$, typical values of N_q and $q = 0.8$ within generalized statistics. The thermodynamic limit is extrapolated in (a) by standard method.

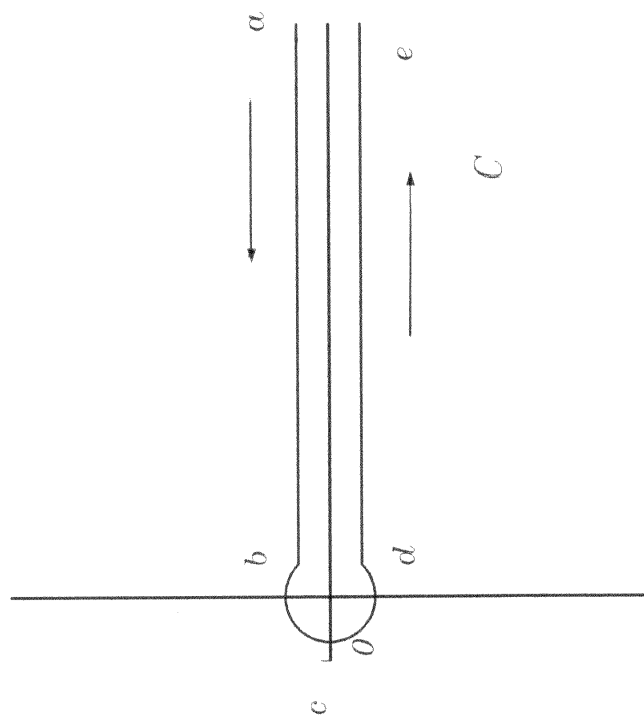

Fig. 1

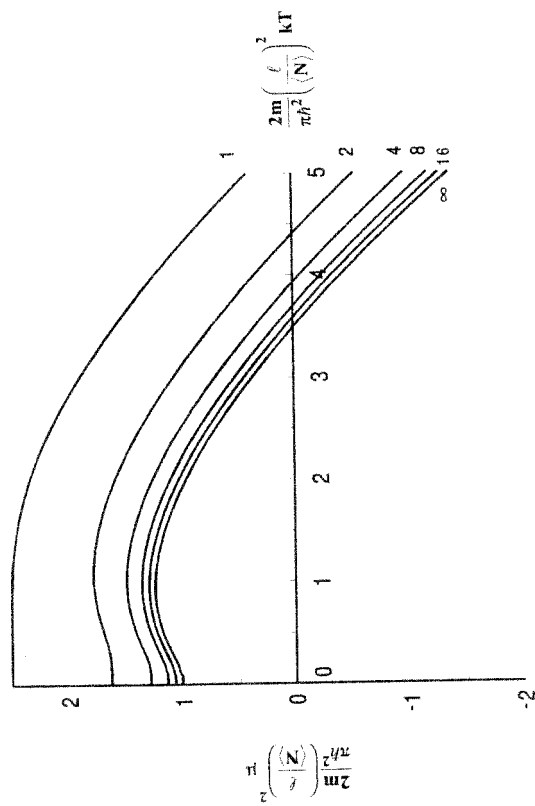

Fig. 2(a)

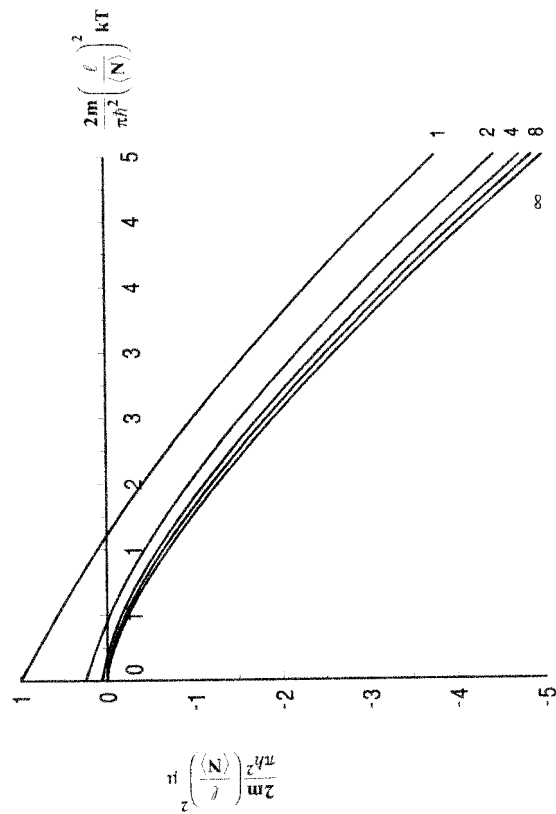

Fig. 2(b)

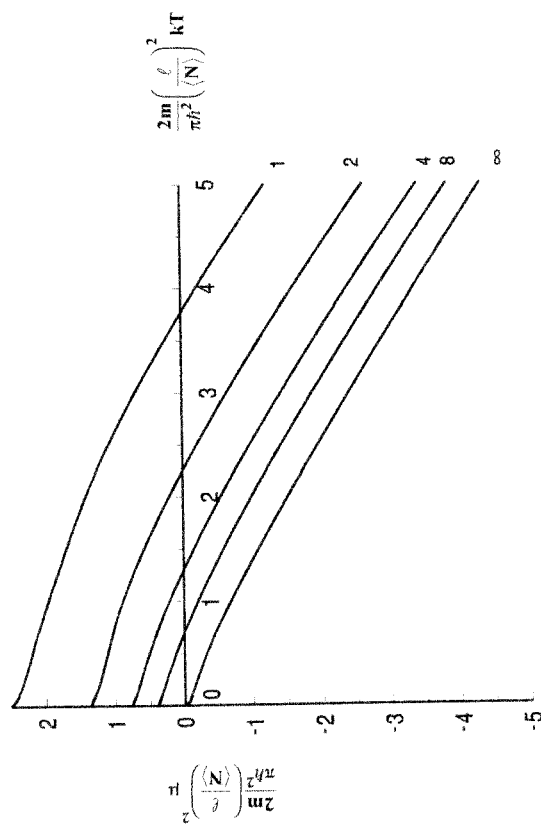

Fig. 3(a)

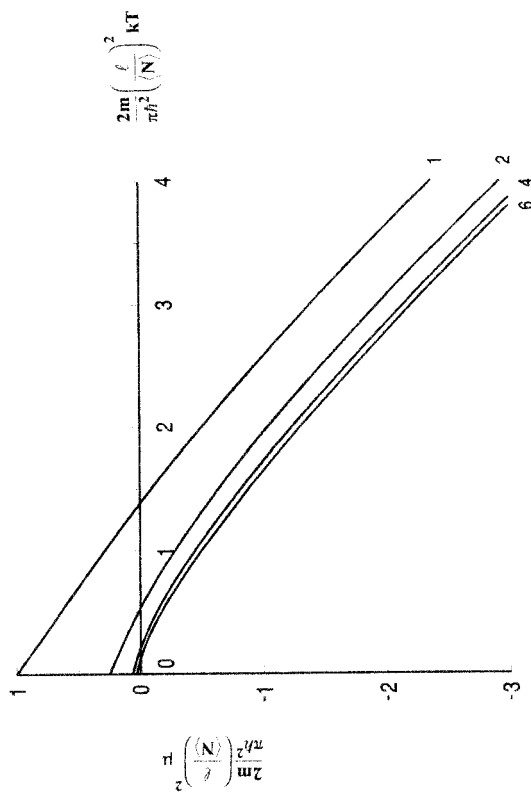

Fig. 3(b)

REFERENCES

- [1] C. Tsallis, J. Stat. Phys. **52**, 479 (1988).
- [2] C. Tsallis, in “New Trends in Magnetism, Magnetic Materials and their Applications”, ed. J. L. Morán-Lopez and J. M. Sánchez, 451 (Plenum Press, New York, 1994).
- [3] C. Tsallis, Chaos, Solitons and Fractals **6**, 539 (1995).
- [4] A. M. Mariz, Phys. Lett. **A 165**, 409 (1992); J. D. Ramshaw, Phys. Lett. **A 175**, 169 (1993); J. D. Ramshaw, Phys. Lett. **A 175**, 171 (1993).
- [5] E. M. F. Curado and C. Tsallis, J. Phys. A: Math. Gen **24**, L69 (1991); Corrigenda: J. Phys. A **24**, 3187 (1991) and **25**, 1019 (1992).
- [6] R. F. S. Andrade, Physica **A 175**, 185 (1991) and Physica **A 203**, 486 (1994).
- [7] E. da Silva, C. Tsallis and E. Curado, Physica **A 199**, 137 (1993) Erratum: Physica **A 203**, 160 (1994).
- [8] N. Ito and C. Tsallis, N. Cim. **D 11**, 907 (1989).
- [9] S. Curilef and C. Tsallis, Physica **A 215**, 542 (1995).
- [10] B.M. Boghosian, “*Thermodynamic description of the relaxation of two-dimensional Euler turbulence using Tsallis statistics*”, preprint (1995). E-mail to chaodyn@xyz.lanl.gov with “get chaodyn/9505012” on subject line.
- [11] A. R. Plastino and A. Plastino, Phys. Lett. **A 174**, 384 (1993).
- [12] J. J. Aly in “*N-Body Problems and Gravitational Dynamics*”, “Proceedings of the Meeting held at Aussois-France”, eds. F. Combes and E. Athanassoula (Publications de l’Observatoire de Paris), 19 (21-25 March, 1993).
- [13] A.R. Plastino and A. Plastino, Phys. Lett. A **193**, 251 (1994).
- [14] P. A. Alemany and D. H. Zanette, Phys. Rev. **E 49**, 956 (1994).

- [15] C. Tsallis, A.M.C. de Souza and R. Maynard, in “Lévy flights and related topics in Physics”, eds. M.F. Shlesinger, U. Frisch and G.M. Zaslavsky (Springer, Berlin, 1995), in press.
- [16] D.H. Zanette and P.A. Alemany, Phys. Rev. Lett (1995), in press.
- [17] C. Tsallis, S.V.F Levy, A.M.C. de Souza and R. Maynard “ *On the statistical-mechanical foundation of the ubiquity of Lévy distributions in Nature*”, preprint (1995).
- [18] C. Tsallis, “*Nonextensive thermostatics—Some new results*”, preprint (1995).
- [19] A.R. Plastino and A. Plastino, “*Non-extensive statistical mechanics and generalized Fokker-Planck equation*”, preprint (1995).
- [20] P. T. Landsberg, in “*On Self-Organization*”, Synergetics **61**, 157 (Springer, 1994).
- [21] C. Miron, *Optimisation par recuit simulé généralisé*, DEA de Physique Statistique et Phénomènes Non Linéaires, Ecole Normale Supérieure de Lyon-France (1994).
- [22] T.J.P. Penna, Phys. Rev. E **51**, R1 (1995).
- [23] D.A. Stariolo and C. Tsallis, Ann. Rev. Comp. Phys., vol. II, ed. D. Stauffer (World Scientific, Singapore, 1995), p. 343.
- [24] T.J.P. Penna, Computers in Physics **9** (May/June 1995), in press.
- [25] C. Tsallis and D.A. Stariolo, “ *Generalized simulated annealing*”, preprint (1995); appeared (in English) as Notas de Fisica/CBPF 026 (June 1994).
- [26] K.C. Mundim and C. Tsallis, “*Geometry optimization and conformational analysis through generalized simulated annealing*”, preprint (1995).
- [27] S.A. Cannas, D. Stariolo and F.A. Tamarit, “*Learning dynamics of simple perceptrons with non-extensive cost functions*”, preprint (1995).

- [28] A. R. Plastino and A. Plastino, Phys. Lett. **A 177**, 177 (1993).
- [29] A. R. Plastino and A. Plastino, Physica **A 202**, 438 (1993).
- [30] D. A. Stariolo, Phys. Lett. **A 185**, 262 (1993).
- [31] E. F. Sarmiento “*Generalization of Single-Site Callen’s Identity Within Tsallis Statistics*”, preprint (1995).
- [32] A. Chame and E. V. L. de Mello, J. Phys. **A 27**, 3663 (1994); A. Chame and E. V. L. de Mello, “*The Onsager Reciprocity Relations within Tsallis Statistics*”, preprint (1994); M. O. Cáceres, Physica A (1995), in press.
- [33] C. Tsallis, Phys. Lett. **A 195**, 329 (1994).
- [34] M. Portesi and A. Plastino, “*Entropic formulation of uncertainty for quantum measurements with Tsallis entropy*”, preprint (1995).
- [35] A.K. Rajagopal, “*The Sobolev inequality and the Tsallis entropic uncertainty relation*”, preprint (1995).
- [36] C. Tsallis, Fractals **3** (September 1995), in press.
- [37] D.H. Zanette, “*Generalized Kolmogorov entropy in the dynamics of multifractal generation*”, preprint (1995).
- [38] P. Ziesche, in *Information: New questions to a multidisciplinary concept*, eds. K. Kornwachs and K. Jacoby (Akademie Verlag Berlin, 1995), in press.
- [39] A.K. Rajagopal, Physica B (July/August 1995), in press.
- [40] A.R. Plastino, A. Plastino and C. Tsallis, J. Phys. A: Math. Gen **27**, 1 (1994).
- [41] D. Prato, Phys. Lett. **A 203**, 165 (1994).
- [42] F. Büyükkiliç and D. Demirhan, Phys. Lett. **A 181**, 24 (1993); F. Büyükkiliç, D. Demirhan and A. Güleç, Phys. Lett. **A 197**, 209 (1995).