

CBPF-NF-011/81

LOCALIZED STATES IN POLYMERIC MOLECULES.
II: APPLICATIONS TO CHEMICAL AND BIOLOGICAL
PROCESSES*

by

H.S.Brandi¹, B.Koiller¹ and R. Ferreira

¹Departamento de Física
Pontifícia Universidade Católica do Rio de Janeiro
Cx. P. 38071, Rio de Janeiro - RJ - Brasil

Centro Brasileiro de Pesquisas Físicas/CNPq
Av. Wenceslau Braz, 71, fundos
22290 - Rio de Janeiro - RJ - Brasil

* This work has been partially supported by the Brazilian Agencies FINEP and CNPq.

LOCALIZED STATES IN POLYMERIC MOLECULES.II: APPLICATIONS TO
CHEMICAL AND BIOLOGICAL PROCESSES*

H.S.Brandi, B.Koiller

Departamento de Física, Pontificia Universidade Católica do
Rio de Janeiro, Cx.P. 38071, Rio de Janeiro, RJ, Brasil

R.Ferreira

Centro Brasileiro de Pesquisas Físicas/CNPq, Av.Wenceslau Braz,
71-fundos, 22290 - Rio de Janeiro, RJ, Brasil

*This work has been partially supported by the Brazilian Agencies
FINEP and CNPq.

Abstract

We present a simple real space method, based on the Green's function formalism, which is convenient for the calculation of the electronic structure of polymers with broken translational symmetry. The method is applied to the study of a model Hamiltonian which may describe conformational modifications of polymeric molecules. The possible role of localized states in chemical and biophysical processes is discussed.

1. Introduction

Macromolecules may represent the simplest systems showing the balance of permanence and mutation which is essential to life processes. The manifold importance of biopolymers is partly expressed in their capacity to undergo chemical reactions as well as to play the important role of biocatalysts (enzymes). It has been recently proposed [1,2] an orbital perturbation approach to enzymatic catalysis, in which the substrate-induced conformational changes [3] are coupled to the electronic eigenstates of the enzyme. These "induced-fit" changes are considered as collisional distortions of the enzyme molecules which allow for the existence of electronic states in previously forbidden regions.

Some years ago Koster and Slater [4] analyzed the effect of reducing the short-range order of crystal lattices; in particular they were concerned with the existence of localized impurity levels in the electronic structure of the system. More recently this problem has been studied by Morton-Blake [5] for a one-dimensional homopolar linear chain (polymer). In the preceding work [6] we introduce the concept of transfer matrix for 1d-systems with long range coupling, and apply this technique to the linear chain problem, for which an analytic solution is obtained. The inclusion of only nearest-neighbors coupling is a good approximation if the interaction decays as $1/r^3$ (or faster) [6].

In the present work, we consider a two band model Hamiltonian, which mimics the valence and conduction electronic

states of a polypeptide chain, and study the modifications in the electronic structure of the system induced by local conformational changes. These modifications describe possible mechanisms for chemical reactions which occur during collisions between polymers and reacting molecules.

2.Theory

We describe a nonperturbed polypeptide chain by an infinite alternative sequence of two types of radicals, A and B, along a chain (fig.1(a)). We take, at each lattice site ℓ , the chemically active molecular orbital for the radical at the site, $|\chi_\ell\rangle$. We assume that $\{|\chi_\ell\rangle\}_{\ell=-\infty, \infty}$ constitutes a complete orthonormal set to describe the electronic properties related to the chemical properties under consideration. The model Hamiltonian, within the one orbital per site and nearest-neighbors coupling approximation, is written in the site representation as:

$$H_0 = \sum_{\ell=-\infty}^{\infty} \epsilon_\ell a_\ell^+ a_\ell + \beta \sum_{\ell=-\infty}^{\infty} \sum_{\delta=\pm 1} a_\ell^+ a_{\ell+\delta} \quad (1)$$

where a_ℓ^+ (a_ℓ) creates (destroys) the proper molecular orbital $|\chi_\ell\rangle$; the eigen energy $\epsilon_\ell = \alpha$ or $-\alpha$ according to whether site ℓ is occupied by species A or B (the energy origin is chosen midway between the two eigen energies) and β is the resonance integral between neighboring A and B molecular orbitals.

The spectrum associated to Hamiltonian (1) is constituted by two bands [7], corresponding to the energy regions $[-\sqrt{\alpha^2+4\beta^2}, -\alpha]$, $[\alpha, \sqrt{\alpha^2+4\beta^2}]$. The lower region corresponds to the valence band,

and is mostly of B-like character, while the upper region, the conduction band, has A-like character. Notice that this model yields bands of the same width.

We consider that during the collision of this chain with a reacting species C, a local configurational deformation may be simulated by the "kink" represented in fig.1(b).

Such a deformation is introduced in the model Hamiltonian in two ways: modifying by δ the self energy of site 0: $\epsilon_0 = -\alpha + \delta$, and considering a resonance integral γ between sites +1 and -1. For simplicity the other parameters are assumed to remain unchanged. The broken symmetry around site 0 causes the appearance of localized electronic states which split-off the continuum. The eigenvalues of these states are easily found by calculating the poles of the Green's function associated to the model Hamiltonian. The Green's function matrix elements in the basis set $\{|\chi_\ell\rangle\}$ may be obtained from Dyson's Equation, solved by the standard transfer matrix approach (see Appendix). Defining $G_{ij} \equiv \langle \chi_i | G | \chi_j \rangle$, the diagonal elements associated to the impurity site and its nearest neighbors are given by:

$$G_{00} = \frac{(E - \alpha - \gamma - \beta T_1(E))}{D_S(E)} \quad (3)$$

$$G_{11} = \frac{(E + \alpha - \delta)(E - \alpha - \beta T_1(E)) - \beta^2}{D_S(E) D_p(E)} \quad (4)$$

where

$$D_S(E) = (E + \alpha - \delta)(E - \alpha - \gamma - \beta T_1(E)) - 2\beta^2 \quad (5)$$

$$D_p(E) = (E - \alpha + \gamma - \beta T_1(E)) \quad (6)$$

and

$$T_1(E) = \{(E^2 - \alpha^2) \pm [(E^2 - \alpha^2)(E^2 - \alpha^2 - 4\beta^2)]^{1/2}\} / [2\beta(E + \alpha)] = \frac{E - \alpha}{E + \alpha} T_2(E) \quad (7)$$

The sign of the square root is plus in the lower band and in the gap, and minus elsewhere.

The poles of G_{00} , i.e., the roots of $D_s(E)=0$, correspond to the energies of the localized eigenstates symmetric with respect to site 0 (or s-like). Antisymmetric (or p-like) states have zero amplitude at site 0, and therefore their energies correspond to the poles of G_{11} which are not present in G_{00} ; they are given by the roots of $D_a(E)=0$.

In the numerical applications below, we have in mind a compound like polyglycine, for which the bandwidth (BW) and gap (G) available in the literature are given in Table I [8,9,10]. We take $\alpha=2\beta$, which yields equal bandwidths of 0.83β and a gap of 4β so that the ratio $G/BW=4.8$, which is reasonable as compared to the values obtained from Table I. It is also convenient to take β as the energy unit.

3. Results and Discussions

We consider initially the simplest kind of perturbation for the proposed model, which consists of just modifying the diagonal term in the central site by δ , and keeping $\gamma=0$. Of course this type of perturbation produces only s-like localized states. The eigen energies of these states are given, as a function of δ/β , in fig.2. Notice that these eigen - energies may correspond to any point in the originally "forbidden" energy

region, depending on the value of δ .

For $\gamma \neq 0$, antisymmetric or p-localized states are obtained, which are of course independent of δ . The eigen-energies of the p states as a function of γ/β are presented by the full line in fig.3; similarly to the case discussed above, they may also correspond to any point in the "forbidden" energy region, depending of γ . The s-like states are a function of both γ and δ : in fig.3 we just consider the γ -dependence of their eigen energies for two different values of δ/β given by the interrupted lines. It is interesting to notice that in the central gap region there is a crossing of s and p states for increasing values of γ/β .

The results presented in figs.2 and 3 correspond to the kink centered around a B-site (fig.1b). However, the results for a kink around an A-site are easily obtained by simultaneously changing the sign of E , δ and γ (see eqs. (5) and (6)), which corresponds to an inversion of figures 2 and 3 with respect to the origin.

For the chemical and biological applications we have in mind, it is convenient to visualize a molecule C being scattered by a polymer AB, in which it induces a time dependent conformational deformation simulated by a parametrization in time t $\gamma(t)$ and $\delta(t)$ so that $\gamma(\pm\infty)=0$ and $\delta(\pm\infty)=0$. Two different situations are described below:

(i) Collisions $C+AB$ in which τ_D , the detachment time of molecule C, is much larger than τ_R , the life-time for the relaxation of the polymer back from its kink ($\tau_D \gg \tau_R$). In this case, states of definite symmetry split off the continuum: states ori

ginating from the valence band are occupied, while those arising from the conduction band are empty states. The eigen energies of these states fall in the "forbidden" region, that is, localized states of any given symmetry, energy and occupation may be produced by a conformational distortion of this kind.

The role of localized states in some chemical and biological processes has been discussed by several authors in different contexts. We mention for instance the induced-fit changes caused by substrate molecules (C) modifying the spatial configuration of the enzyme molecules (polymer AB)[3].

These changes are essential to the catalytic action [11] and it has been argued [1,2] that they play an important role by causing significant shifts in some critical electronic levels of the enzymes. A mechanism of the type described in (C) may qualitatively account for this type of process, as well as to represent theoretically an alternative description of the effect of an impurity in a linear chain.

In fact some authors [2,12,14] have argued that the role of transition element ions, (Fe(II), Fe(III), Zn(II)etc) which exist in small concentrations ($\sim 10^2$ per aminoacid) in the metalloproteins, is very similar to the effect of impurities in semiconductors. The appearance of localized states in "forbidden" energy regions allows the action of metalloproteins as enzymes, catalyzing electron transfer processes.

Of course processes such as those described in (i) could also be of catalytic importance.

(ii) Collisions C+AB in which the detachment time of C is much smaller than the relaxation time for the polymer to e

eliminate the "kink" ($\tau_D \ll \tau_R$). As shown in fig.3, for physically reasonable values of the perturbation parameters δ/β and γ/β , it is possible to produce degenerate states of different symmetries. In the presence of the perturbing potential of molecule C, the transition probability for an electron in the state originating from the valence band to be transferred to the originally empty state originating from the conduction band becomes quite large (15). Therefore, if $\tau_D \ll \tau_R$, the reverse process is inhibited due to the absence of C, and the final state of the polymer may correspond to an excited electronic configuration with an electron promoted to the conduction band and a hole in the valence band. If the polymer is part of a cell membrane, its electric conductivity would drastically increase after the scattering process. This may happen for example in the synapsis between an axon and a muscle cell. Molecules of acetylcholine, released from the axon, attach to polymeric materials of the muscle cell membrane thereby reducing to zero the "action potential difference" of ~ 80 mV [16]. This depolarization of the cell membrane gives origin to the contracting impulse along the muscle. It is known that acetylcholine molecules are attached to the acceptor region for a short time, being hydrolyzed by acetylcholinesterase, and the muscle cell membrane is restored to its polarized state.

4. Conclusion

We have proposed a semi-quantitative model for mechanisms which may occur in the context of chemical reactions, associated to conformational changes induced by collisions with subs -

trate molecules. The application of the model to real situations would require more detailed quantitative information about the processes discussed in section 3, so that more realistic versions could be formulated. The flexibility of the transfer function technique allows an equally simple treatment of more sophisticated systems, which could include, for example, more than two species in the chain, or different types of deformations. However, since our main physical conclusions are not expected to change, more elaborate models are justified only under the guidance of more specific experimental details.

Appendix

The Hamiltonian matrix elements relative to the basis set $\{|\chi_\ell\rangle\}$ corresponding to the "kink" model (fig.1(b)) are:

$$\langle \chi_i | H | \chi_j \rangle = H_{ij} = \begin{cases} -\alpha + \delta, & i=j=0 \\ (-1)^{i+1} \alpha, & i=j \neq 0 \\ \beta, & i=j \pm 1 \\ \gamma, & i=\pm 1, j=\mp 1 \end{cases} \quad (\text{A.1})$$

Making use of Dyson's equation in this basis set:

$$EG_{ij} = \delta_{ij} + \sum_{\ell} H_{i\ell} G_{\ell j} \quad (\text{A.2})$$

we obtain the equations related to G_{00} :

$$(E + \alpha - \delta) G_{00} = 1 + \beta(G_{10} + G_{-10}) \quad (\text{A.3-a})$$

$$(E - \alpha) G_{10} = \beta G_{00} + \beta G_{20} + \gamma G_{-10} \quad (\text{A.3-b})$$

$$[E + (-1)^n \alpha] G_{n0} = \beta G_{n-1,0} + \beta G_{n+1,0}, \quad |n| \geq 2 \quad (\text{A.3-c})$$

Two transfer functions must be defined to solve this infinite set of coupled equations [7]:

$$T_1(E) = \frac{G_{2n,0}}{G_{2n-1,0}} \quad |n| \geq 1 \quad (\text{A.4})$$

$$T_2(E) = \frac{G_{2n+1,0}}{G_{2n,0}}$$

These functions are easily obtained from (A.3-c), and are given in Eq. [7]; the criterium for the choice of sign is discussed in ref. [7]:

Since, by symmetry, $G_{10} = G_{-10}$, and making use of (A.4), we may write (A.3-a) and (A.3-b) as:

$$(E + \alpha - \delta)G_{00} = 1 + 2\beta G_{10} \quad (A.5)$$

$$(E - \alpha - \gamma)G_{10} = \beta G_{00} + \beta T_1 (E)G_{10}$$

from which G_{00} , given in eq. [3], is obtained.

The diagonal matrix element associate to site 1 is obtained from the system:

$$\begin{aligned} (E - \alpha)G_{11} &= 1 + \beta(G_{21} + G_{01}) + \gamma G_{-11} \\ (E + \alpha - \delta)G_{01} &= \beta(G_{11} + G_{-11}) \\ (E - \alpha)G_{-11} &= \beta(G_{-21} + G_{01}) + \gamma G_{11} \\ [E + (-1)^n \alpha]G_{n,1} &= \beta G_{n-1,1} + \beta G_{n+1,1}, \quad |n| \geq 2 \end{aligned} \quad (A.6)$$

which is solved in the same way as (A.3). The expression for G_{11} is given in eq. [4].

References

1. Gomes, M.A.F., Gama, A.A.S. and Ferreira, R., Chem. Phys. Letters 53, 499 (1978); *ibid* 57, 259 (1978).
2. Gomes, M.A.F. and Ferreira, R., Phys. Letters 77A, 384 (1980).
3. Koshland, Jr. D.E., "The Enzymes", P.D. Boyer, H. Lardy and K. Myrback, eds., Academic Press, New York, vol.1, 1959, pp. 305-346.
4. Koster, G.F. and Slater, J.C., Phys. Rev. 95, 1167 (1954); *ibid* 96, 1208 (1954).
5. Morton-Blake, D.A., Theor. Chim. Acta (Berl.)56, 93 (1980); Int. J. Quantum Chem. 18, 937 (1980).
6. Koiller, B. and Brandi, H.S. - Paper I of this series (submitted to this Journal).
7. Koiller, B. and Falicov, L.M., Phys. Rev. B13, 4387 (1976).
8. Evans, M.G., and Gergely, J., Bioch. Biophys. Acta, 3, 188 (1949).
9. Morokuma, K., Chem. Phys. Letters, 9, 129 (1971).
10. Ladik, J., Suhai, S., and Seel, M., Int. J. Quant. Chem., Quant. Biol. Symp., 5, 35 (1978).
11. B.A.Peters, and Neet, K.E., J.Biol.Chem., 253, 6826 (1978).
12. Hopfield, J.J., Proc. Nat. Acad. Sci. USA 71, 3640 (1974); Biophys. J. 18, 311 (1977).
13. Brill, A.S., Biophys. J. 22, 139 (1978).
14. Potasek, M.J., Science 201, 151 (1978).
15. Merzbacher, E., "Quantum Mechanics", Wiley Intern. Edition (2nd edition) p.479.
16. See, for example, Stryer. L, "Biochemistry", W.H. Freeman and Co., San Francisco, 1975, pp. 788-791.

Figure Captions

Fig.1 - Schematic representation of (a) the undistorted polymer and (b) the "kink" conformation. The diagonal and resonance Hamiltonian parameters are indicated.

Fig.2 - Eigen energies E_s of the localized states as a function of the "kink" perturbation parameter δ/β , for $\gamma=0$. The energy bands are given by the shaded regions.

Fig.3 - Eigen energies of the symmetric (s) and antisymmetric (p) localized states as a function of the "kink" perturbation parameter γ/β , for $\delta/\beta=1$ and 2.

Table Caption

Table I - Results obtained from band theory calculation for polyglycine.

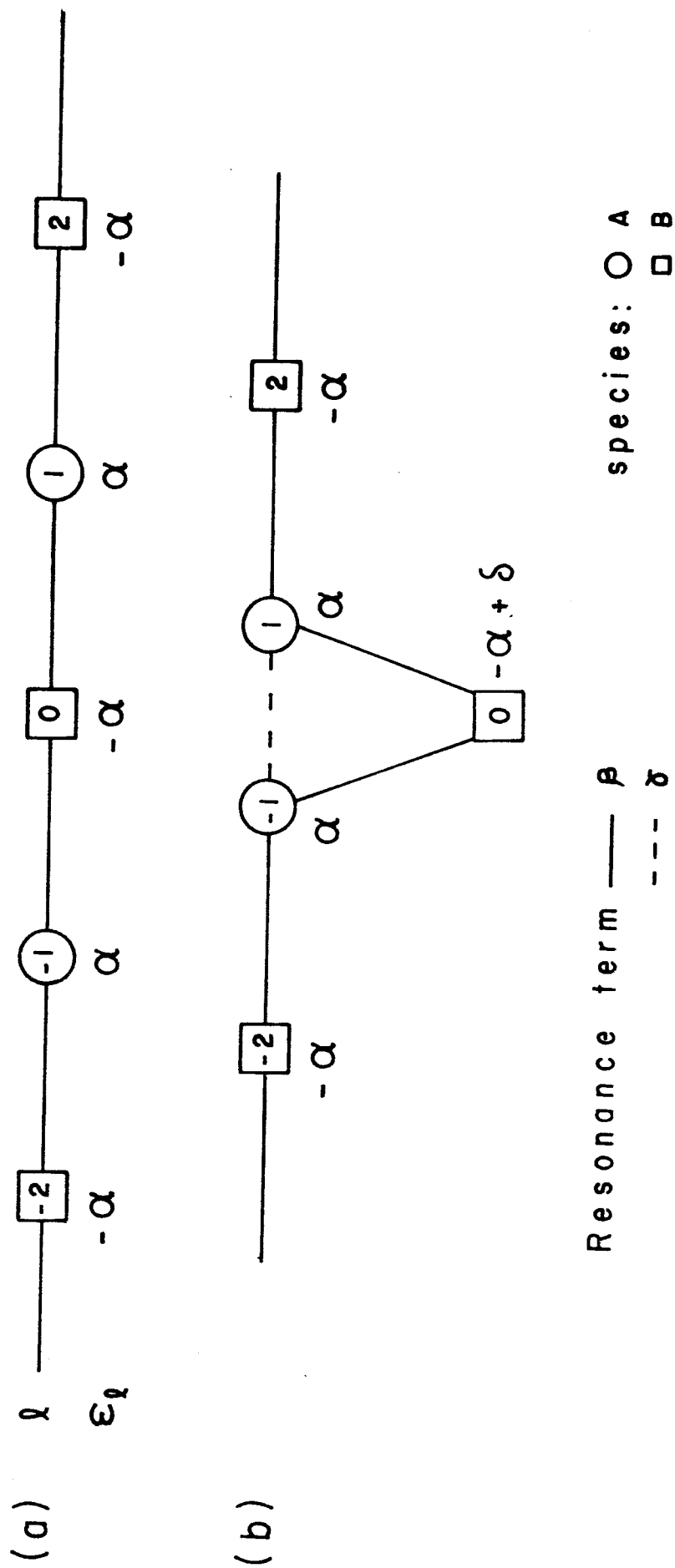

Fig. 1

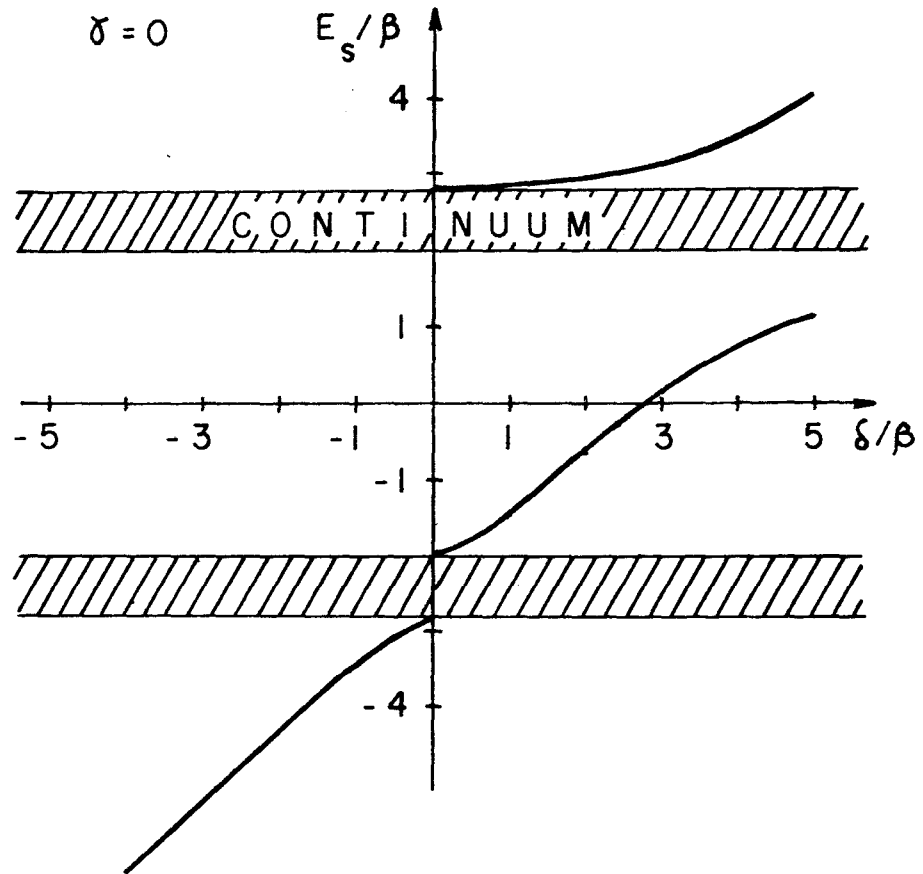

Fig. 2

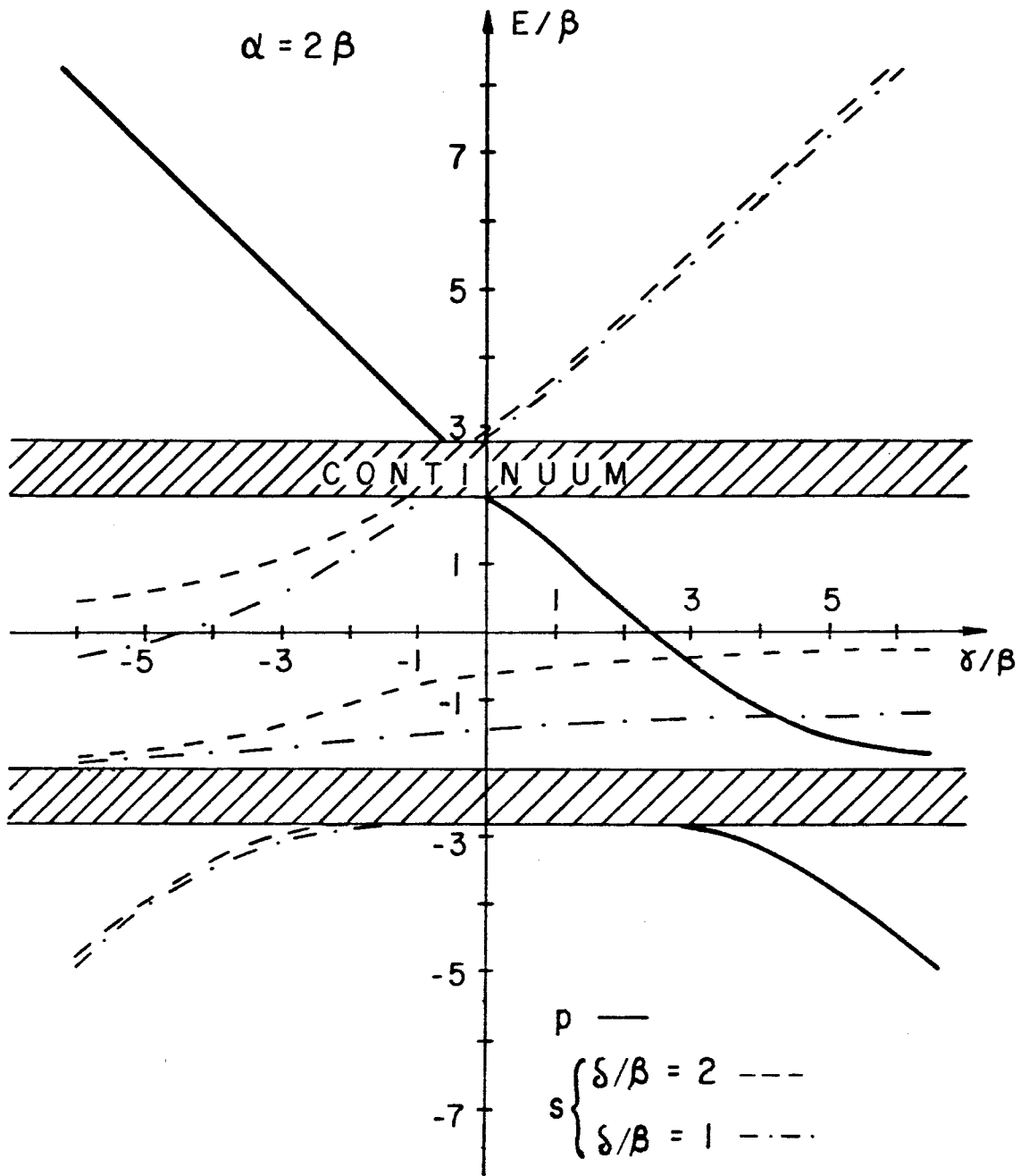

Fig. 3

Table I
 Results obtained from band theory calculations
 for polyglycine

VALENCE BAND WIDTH (eV)	CONDUCTION BAND WIDTH (eV)	ENERGY GAP (eV)	REF.
0.12	0.26	3.0	[8]
-	-	6.1-16.7	[9]
2.1	1.4	8.5- 11.6	[10]